

MECHANICAL ALUMINIUM LUG (CENTRED PALM)

A bolted alternative which does not require crimping tool or high operator skill.

Bolts are torque-controlled to ensure clean and right shear-offs for a good contact.

Solid palm eliminates ingress of moisture.

Made from high strength Aluminium alloy. Surface is electro tin-plated.

All lugs are pre-filled with jointing compound and individually labeled.

Suitable for a wide range of LV and MV applications.

Approved with TNB Certificate of Product Acceptance (SGP).

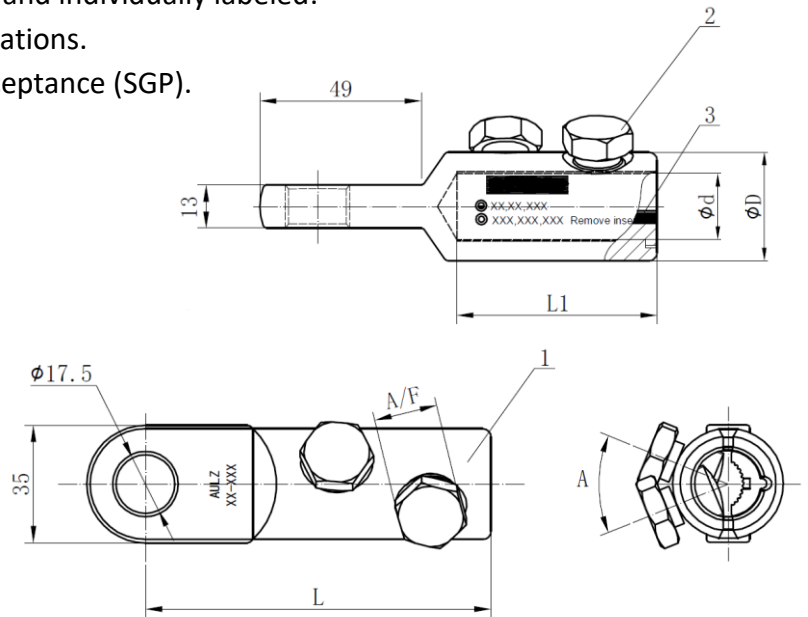

Conductor Size Range (mm ²)	Item Code	Stud Hole (mm)	No. of Bolts	Wrench Size	Dimensions (mm)					
					D	d	L1	L	A	AF
25-95	MLCA-AULZ25-95-XX/1L	17.5	1	13	24	13.3	32	71	/	13
70-240	MLCA-AULZ70-240-XX/2L	17.5	2	19	33	20	61	103	44°	19
185-400	MLCA-AULZ185-400-XX/3L	17.5	3	22	42	26	78	126	44°	22
300-630	MLCA-AULZ300-630-XX/3L	17.5	3	22	52	33	90	140	44°	24