

MECHANICAL CONNECTOR

A bolted alternative which does not require crimping tool or high operator skill. Bolts are torque-controlled to ensure clean and right shear-offs for a good contact. Made from high strength Aluminium alloy. **Surface is electro tin-plated.** It is suitable for jointing of Aluminium or Copper cables. All Ferrules are pre-filled with jointing compound and individually labeled. Suitable for a wide range of LV and MV applications.

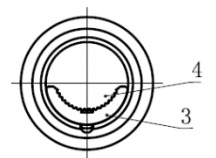
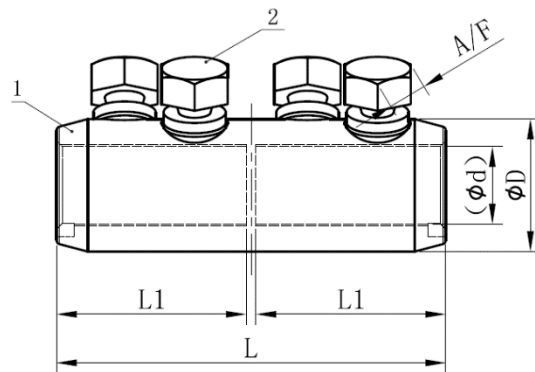
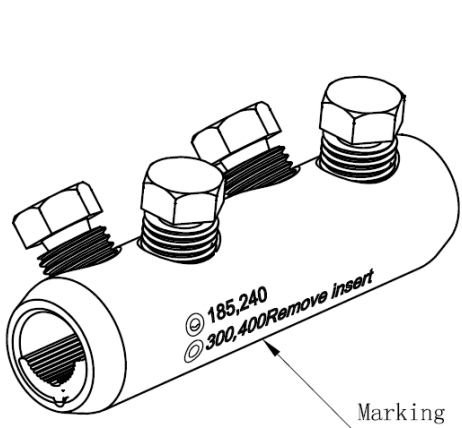

Component List

- 1 – Connector Body (Aluminium alloy)
- 2 – Bolt (Aluminium alloy)
- 3 – Insert (Aluminium alloy)
- 4 – Contact Grease

Conductor Size Range (mm)	Item code	Dimensions (mm)					Number of Bolts
		L	L1	D	d	A/F	
25-95	MCGA-GLL25-95/2L	70	33.5	24	13.3	13	2
35-150	MCGA-GLL35-150/4L	106	51.5	28	16	17	4
70-240	MCGA-GLL70-240/4L	125	61	33	20	19	4
120-300	MCGA-GLL120-300/4L	140	68	38	24	22	4
185-400	MCGA-GLL185-400/6L	170	83	42	26	22	6
300-630	MCGA-GLL300-630/6L	200	97	52	33	24	6

