

OUTDOOR CABLE LUG (SOLDER SEALED)

Specially designed for outdoor terminations.
No peep-hole and palm is solder-sealed to stop ingress of water and oil.

Use for Copper Conductor.
Crimp Type for Hexagon and Indent Die.
Suitable for Low and Medium Voltage application.

High Conductivity Copper : 99% I.A.C.S
Copper Purity : 99.9%
Finishing : Tin Plated

Copper tube compliant to MS1540.

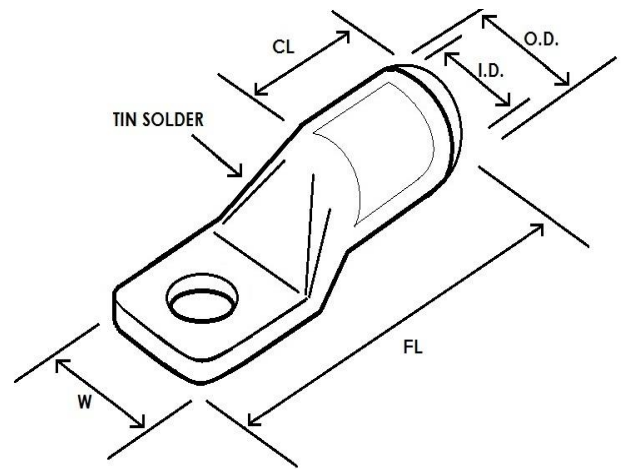

Size	Stud Hole	Item code	FL	CL	OD	ID	W	Crimping Tool	Hexag on Die A/F	No. Of Crimps
50mm ²	M10	CLOD-50-10	55	22	12.5	9.5	18.0	TCCP-300	10.3	1
70mm ²	M12	CLOD-70-12	63	25	14.4	11.2	20.5	TCCP-300	11.9	1
95mm ²	M12	CLOD-95-12	66	25	17.5	13.5	25.0	TCCP-300	14.5	1
120mm ²	M12	CLOD-120-12	73	27	19.0	14.6	28.0	TCCP-300	15.7	2
150mm ²	M16	CLOD-150-16	78	30	21.4	16.4	31.5	TCCP-300	17.6	2
185mm ²	M16	CLOD-185-16	82	32	23.7	18.5	35.0	TCCP-300/630	19.5	2/ 1
240mm ²	M16	CLOD-240-16	115	50	27.4	21.0	40.0	TCCP-300/630	22.6	3/ 2
300mm ²	M16	CLOD-300-16	121	50	30.5	23.5	45.0	TCCP-630	25.2	2
400mm ²	M16	CLOD-400-16	139	60	34.0	26.2	50.0	TCCP-630	28.5	2
500mm ²	M20	CLOD-500-20	158	65	38.6	30.0	55.0	TCCP-630	32.1	3
630mm ²	M20	CLOD-630-20	161	65	44.7	34.5	64.0	TCCP-630	37.0	3

Notes:

1. All dimensions are in mm.
2. Other dimension customizations are available upon request.
3. Please consult with our sales personnel before order.

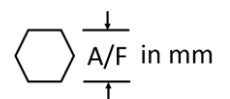

CONWAY
Connecting Power

Tel : +6 03 5569 0600
H/P : +6 012 506 1068

Email : ask@conway.com.my
Web : www.conway.com.my